



AI Computing Platform

9F1E1

Datasheet



Version V2.2

Date 2026-01-19

Copyright by Beijing Plink-AI Technology Co., LTD.2023.All rights reserved.

No part of this document may be reproduced or transmitted in any form or by any means without prior written consent of Plink-AI Technologies Co., Ltd.

Notice

The purchased products, services and features are stipulated by the contract made between Plink-AI and the customer. All or part of the products, services and features described in this document may not be within the purchase scope or the usage scope. Unless otherwise specified in the contract, all statements, information, and recommendations in this document are provided "AS IS" without warranties, guarantees or representations of any kind, either express or implied.

The information in this document is subject to change without notice. Every effort has been made in the preparation of this document to ensure accuracy of the contents, but all statements, information, and recommendations in this document do not constitute a warranty of any kind, express or implied.

Please scan code for more products



Website



Official Accounts



WeChat Channel

Beijing Plink-AI Technology Co., LTD

Web: <http://www.plink-ai.com/>

Add: Room 1108, Jinyu Jiahua Building, Shangdi 3rd Street, Haidian District, Beijing

Tel: +86-010-62962285/400-127-3302

Document History

Version	Date	Description of Change	Hardware Versoin
V 1.0	2022-3-24	<ol style="list-style-type: none"> 1. Update the product introduction; 2. Add product ordering information; 3. Add AGX ORIN related parameters. 	V 1.0
V 2.0	2024-02-29	<ol style="list-style-type: none"> 1. Change the product manual template; 2. Change product description; 3. Add interface functional test description. 	V 1.0
V 2.1	2025-01-09	<ol style="list-style-type: none"> 1. Modify font 	V 1.0
V 2.2	2025-01-19	<ol style="list-style-type: none"> 1. Modify Dimension Figure 	V 1.0

Hardware Update History

Version	Date	Description of Change
V 1.0	2022-3-24	Initial Version



Electronic components and circuits are very sensitive to electrostatic discharge, although the company will design the main interface on the board card to do anti-static protection design, but it is difficult to do anti-static safety protection for all components and circuits. Therefore, it is recommended that you take ESD safety measures when handling any circuit board component.

ESD safety measures include but are not limited to the following:

1. Put the card in an ESD bag during transportation or storage. Do not take out the card until installation and deployment.
2. Before touching the board, release the static electricity stored in the body: Wear a grounding wrist strap.
3. Operate circuit boards only in electrostatic discharge safe areas.
4. Avoid moving circuit boards in carpeted areas.
5. Avoid direct contact with electronic components on the board through edge contact.

Table of Contents

1	Introduction	6
2	Specifications	7
3	External I/O Ports	9
4	Dimension Figure	11
5	Ordering Information	12
6	Recovery Mode	12
7	Method of Application	13
8	Special Instructions	13

1 Introduction



9F1E1 is a rugged AI industrial PC that can be used with NVIDIA® Jetson™ AGX Xavier/AGX Orin core modules. The main interface is designed for electrostatic safety protection, using a high-reliability power application scheme, the input power supply has overvoltage and reverse polarity protection function, with a variety of external interfaces, internal interface devices are wide temperature model.

9F1E1 standard can support the expansion of multiple full-speed Gigabit Ethernet, support the expansion of USB3.0 signal, SSD memory card, SATA signal, 4G communication module, all kinds of video acquisition/output cards, AD acquisition cards, multiple serial port cards, sound acquisition/output cards, multi-function IO cards, etc. (The standard products do not include the above expansion functions. Please contact sales for extensions).

2 Specifications

	Specific
Carrier Board	Y-C9
Module	NVIDIA Jetson AGX Orin / AGX Xavier Serial Module
Temperature	-20°C ~ +55°C
Dimensions (L×W×H)	166.7mm*135mm*74.5mm (L/W Not Including I/O ports and mounting holes)
Weight	1061g

Power Supply	Spec
Input Type	DC
Input Voltage	+12V

I/O Ports

Interface	Quantity	Interface	Quantity
USB3.0 Type-A	3	Micro USB	1
RJ45	1	HDMI 2.0	1
USB Type-C	1	Power Button	1
Recovery Button	1	Reset Button	1
Built-in miniPCle	2	Built-in M.2 Key M(2280)	1

Note: When used with Jetson AGX Orin module, only one USB Type-A supports 3.0 full speed, the rest are USB 2.0, the internal RTC function is not available, and the built-in interface one miniPCle is not available.

NVIDIA Jetson Series Modules Technical Specifications

Module	Jetson AGX Xavier 32GB	Jetson AGX Xavier 64GB	Jetson AGX Orin 32GB	Jetson AGX Orin 64GB
AI Performance	32 TOPS		200 TOPS	275 TOPS
GPU	512-core NVIDIA Volta architecture GPU with 64 Tensor Cores		1792-core NVIDIA Ampere architecture GPU with 56 Tensor Cores	2048-core NVIDIA Ampere architecture GPU with 64 Tensor Cores
CPU	8-core NVIDIA Carmel Arm® v8.2 64-bit CPU 8MB L2 + 4MB L3		8-core Arm® Cortex®-A78AE v8.2 64-bit CPU 2MB L2 + 4MB L3	12-core Arm® Cortex®-A78AE v8.2 64-bit CPU 3MB L2 + 6MB L3
Memory	32GB 256-bit LPDDR4x 136.5GB/s	64GB 256-bit LPDDR4x 136.5GB/s	32GB 256-bit LPDDR5 204.8 GB/s	64GB 256-bit LPDDR5 204.8 GB/s
Storage	32GB eMMC 5.1		64GB eMMC 5.1	
Video Encode	4x 4K60 (H.265) 8x 4K30 (H.265) 16x 1080p60 (H.265) 32x 1080p30 (H.265)		1x 4K60 (H.265) 3x 4K30 (H.265) 6x 1080p60 (H.265) 12x 1080p30 (H.265)	2x 4K60 (H.265) 4x 4K30 (H.265) 8x 1080p60 (H.265) 16x 1080p30 (H.265)
Video Decode	2x 8K30 (H.265) 6x 4K60 (H.265) 12x 4K30 (H.265) 26x 1080p60 (H.265) 52x 1080p30 (H.265)		1x 8K30 (H.265) 2x 4K60 (H.265) 4x 4K30 (H.265) 9x 1080p60 (H.265) 18x 1080p30 (H.265)	1x 8K30 (H.265) 3x 4K60 (H.265) 7x 4K30 (H.265) 11x 1080p60 (H.265) 22x 1080p30 (H.265)
Power	10W - 30W		15W - 40W	15W - 60W

3 External I/O Ports



Sign	Function	Sign	Function
USB1	Type A USB3.0 Connector	HDMI	Type-A HDMI Connector
Power	DC 12V Power Jack	LED	Power LED
USB2	Type A USB3.0 (Only USB2.0 is supported when AGX ORIN module is installed)		
RJ45	RJ45 Jack (10/100/1000Mbps Ethernet)		
OTG	Type-C USB2.0 Connector(Only use to flash system)		



Sign	Function	Sign	Function
Debug	Micro USB(Debug Serial Port)	PWR	Power Button
REC	Recovery Button	RST	Reset Button
USB3	Type A USB3.0 (Only USB2.0 is supported when AGX ORIN module is installed)		
<p>Debug serial port default Settings: 115200, 8N1</p>			

4 Dimension Figure

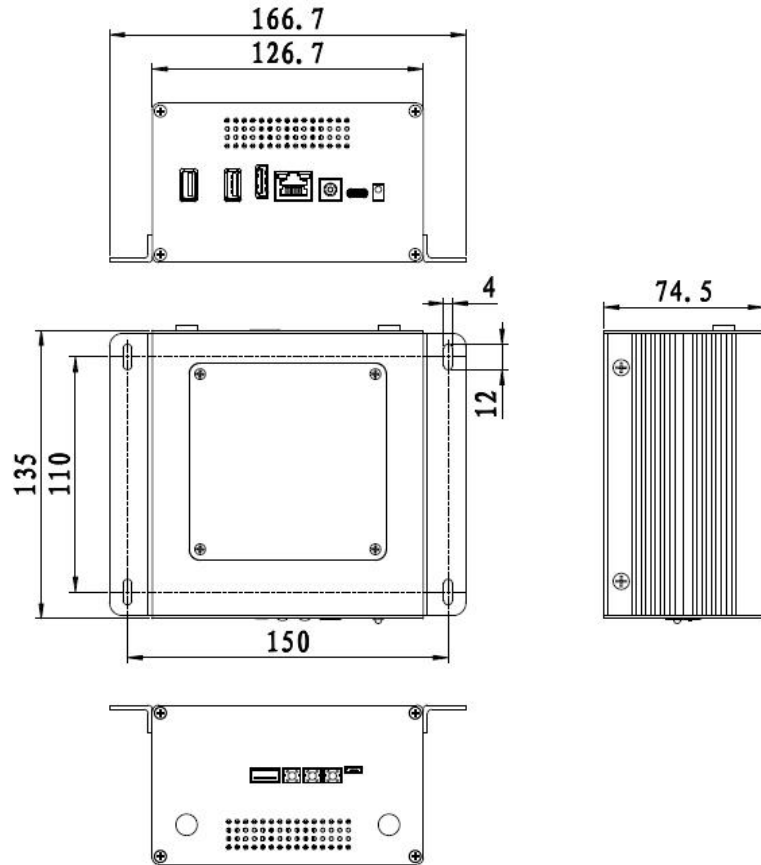

5 Ordering Information

Order Type	Function
9F1E1	Small size AI industrial computer adapted to NVIDIA® Jetson™ AGX ORIN /AGX Xavier series core modules

E-commerce Platform

Taobao Store Address: <https://shop333807435.taobao.com/>

Jingdong Store Address: <https://mall.jd.com/index-11467104.html?from=pc>

Ali International Station Address: <https://plink-ai.en.alibaba.com/>

6 Recovery Mode

Jetson core module can work in normal mode and Recovery mode. In Recovery mode, it can perform file system update, kernel update, Bootloader/UEFI update, BCT update and other operations.

To enter the Recovery mode, perform the following steps:

- Power off the system.
- Use a Micro-USB cable to connect the Micro-USB port (OTG) of the 9F1E1 to the Jetson development host USB port.
- The Jetson development host should be Ubuntu18.04 or Ubuntu20.04 based on X86 architecture.
- Press the Recovery key (REC) to power the system. Hold down the Recovery key (REC) for more than 3 seconds, and then release the Recovery key (REC).
- When the system enters Recovery mode, you can perform subsequent operations.

7 Method of Application

- Make sure all external system voltages are turned off.
- Install necessary external cables. (For example: the display cable to connect to the HDMI monitor, the power input cable to power the system, the USB cable to connect the keyboard and mouse...)
- Connect the power cord to the power supply.
- 9F1E1 is automatically powered on by default. It can also be set to switch start. Please consult our sales and technical personnel for specific methods.

8 Special Instructions

- Initial system username: **nvidia** , password: **nvidia** , no password su. If root permissions are required, use `sudo` to grant permissions, or use `sudo su` to access the root user.
- The pre-installed system is pure by default and does not contain Jetpack software. You can use the following command to install the software. Do not replace or modify the default software source before installation:
 - `sudo apt-get update`
 - `sudo apt-get install nvidia-jetpack`
- It can also be installed over the network using SDKmanager software.
- For more information please refer to :Jetson wiki (plink-ai.com)